



PRINTING Product parameter table

Model	XMS-218X
Printing type	Hot Press Foam Inkjet Technology
Printing method	Single Pass
Color Configuration	CMYK
Number of channels	4
Printing speed	20meters/minute (high speed),5 meters/minute (low speed)
Resolving power	600*300 dpi or 1200*300 dpi
Ink Type	Water-based Pigment Ink
Drying method	Natural drying
Paper feed width	220mm
Print Width	218mm
Print area	Customizable within a range of 220mm
Material thickness	0.1-150mm
Material type	Corrugated board, white board corrugated, paper bags, paper cup sheets, etc.
Material height	615 mm x 360 mm x 315 mm (L×W×H)
Power Supply	220V
Power	0.5KW
Ambient temperature	20-27°C
Ambient humidity	65-80% relative humidity
Correction guide bar	
Material issuing method	Manual material issuance
Production efficiency	2000/day



Note: All information contained in this document is for guidance only, and Chenhao Technology reserves the right to modify it.

Equipment Dimensions

Unit: mm

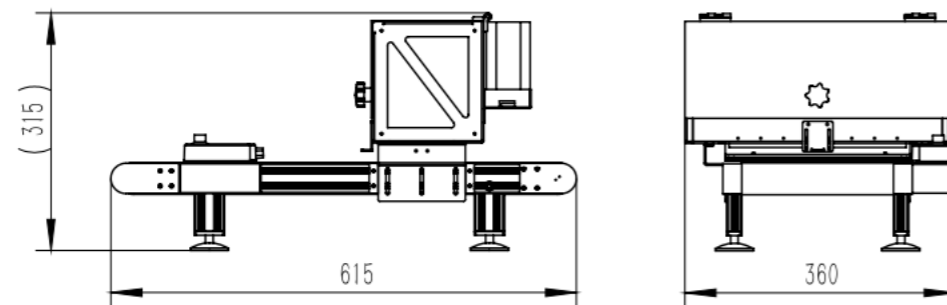

Multi-functional Printing System

MAGIC PRINTING XMS-218X

Digital color printing machine

Personalized small-batch customization, starting from one piece

More time- and labor-efficient compared to traditional printing

Ink has bright colors and is widely suitable for different industries

Compact appearance, easy to use



New Mosheng digital printing (Suzhou) Co., LTD
 Address : Room 105, Building 5, Hexin Zhihui Technology Pioneer Park, No.88 Huyang Road, Suzhou High-tech Zone
 Tel : 17712871289
 WhatsApp : (+86) 17712871289
 Email : haosheng-he@outlook.com
 Website : <https://www.xmsdp.com/>



WhatsApp